

Technical News Feature

Adventures in Membraneland¹

MORRIS KATES, Department of Biochemistry, University of Ottawa, Ottawa, Canada

It is a very great honor to have been awarded the 1984 Supelco AOCS Research Award. To be chosen by one's peers for an award of this kind is indeed the ultimate reward for one's life work, even more so when one considers the stature and level of achievement reached by the previous winners. This award is particularly gratifying to me in recalling that the first awardee was Prof. Erich Baer, who was my Ph.D. supervisor. I think that ever since he won this award in 1964 it has been my aspiration to follow in his footsteps.

I am very happy also to have the opportunity to discuss some of the things I have been doing in research over the years.

Now, where to start? There is a story about Isaac Newton, who was asked how he viewed his life's work. He replied that to himself he seemed to have been only a boy playing on the seashore and now and then picking up a brighter shell or a prettier pebble, while all around lay the great ocean of truth undiscovered.

This is a very surprising statement coming from the man we regard as the father of physics, the discoverer of the laws of motion that bear his name, and many other fundamental concepts. And yet, there is much truth in his statement in the sense that all creative scientists have made discoveries "accidentally" or by serendipity, provided they had the imagination to recognize them as discoveries. A few examples come to mind: Archimedes with his "Eureka," Kekulé with his electronic structure of benzene, Newton himself with his apple, Einstein riding on a beam of light, and Watson and Crick with their double helix.

Modern neurologists recognize this kind of creativity as resulting from "right-brain activity." So in this respect, scientists behave in the same way as artists, poets and musicians, who are well-recognized as being "right-brain" thinkers!

I use this story to indicate that many of the problems that I have worked on and the findings that have come out of this work have more often been the result of serendipity than of deliberate planning.

How did I get into the area of lipid or membrane research in the first place? It happened that as a fourth year physics and chemistry student at the University of Toronto I was assigned to Prof. Hermann O.L. Fischer to do a research project for the bachelor's degree. Prof. Fischer was the son of Emil Fischer, who is considered to be the father of biochemistry. Prof. Fischer and his assistant, Dr. Erich Baer, had left Germany in 1933, just ahead of the Nazis, and settled temporarily in Basle, Switzerland, staying until 1937 when Sir Fredrick Banting arranged for them to join the chemistry department at Toronto; he also arranged laboratory space for them in his Banting Institute.

Fischer and Baer had established an international reputation by developing procedures for synthesizing naturally occurring glycerol derivatives such as acylglycerols and

phosphoric acid esters of glycerol in stereoisomerically pure form. About the time I finished my bachelor's degree project, in 1945, Baer and Fischer decided that the time was ripe to undertake the chemical synthesis of phospholipids to establish their structure and natural stereoconfiguration unambiguously.

I was intrigued with this project, having just learned about phospholipids in a biochemistry course, and I decided to stay on as a graduate student under the supervision of Erich Baer. My project? The synthesis of lecithin, the most widespread of the membrane phospholipids.

Three years later we achieved the first unambiguous chemical synthesis of lecithin that finally established the chemical structure and configuration of this phospholipid as *sn*-3-phosphatidylcholine or, in the old nomenclature, "L- α -lecithin." The synthesis also made lecithin available in pure form for further study by physical chemists, biochemists and medical scientists.

To gain further experience with natural products, I moved on to do postdoctoral research with Léo Marion at the National Research Council (NRC) in Ottawa on the chemical structure of alkaloids. This experience in structure determination, together with the experience in lipid synthesis in Dr. Baer's lab, turned out to be very useful in obtaining my first job in 1951 in the Plant Physiology section at NRC. The NRC wanted someone to work on plant lipids, particularly the chloroplast membrane lipids, and I was delighted to be able to work again in the membrane lipid field.

The Singer "Fluid Mosaic Model" of the membrane is one in which the membrane proteins are embedded in or float on a sea of lipid bilayer forming a pattern or mosaic, the lipid chains being in the liquid crystalline or fluid state. The model would seem to indicate that both the polar heads and lipid chains are uniform in composition. Over the past 20 years or more, the work of many investigators has shown that the composition of both the polar head groups and lipid chains are variable and characteristic of the particular organism or class of organisms. A good deal of my research on membranes over the years concerns this point.

My colleagues and I have studied membrane lipids of bacteria, algae, yeasts, plants and mammalian cells and tissues, and I assure you their lipids are different, sometimes very different! I have chosen three specific examples—two bacteria and a diatom—to illustrate the point.

First I must note that all my research has been carried out in collaboration with colleagues, visiting professors, postdoctoral fellows and graduate students, both at NRC and at the University of Ottawa (Biochemistry Department), which I joined in 1968. In regard to the bacterial studies on halophiles and methanogens, there are my colleagues at NRC who worked with me before I came to the University of Ottawa (Drs. Gibbons, Perry and Kushner) and those with whom I am still collaborating (Drs. Smith and Sprott). At the University of Ottawa I still collaborate with Donn Kushner, who made the move from NRC a few years before

¹The 1984 AOCS Supelco Award Lecture, presented during the 75th annual AOCS meeting, in April 1984, in Dallas, TX.

I did. Apart from Ottawa scientists, there have been collaborative projects with Drs. Ben Volcani of the University of California at La Jolla and with Robert Bittman of New York University.

While at NRC I was fortunate to have a number of excellent postdoctoral fellows who participated in the research I will be describing, and when I came to the University of Ottawa in 1968 I was able to carry on the projects started at NRC, again with the help of postdoctoral fellows and also graduate students. I should mention in particular my graduate student, Dr. Tony Hancock; Dr. Santosh Kushwaha who worked with me for 10 years as a research associate on halophile and methanogen lipids; Dr. Robert Anderson who worked as a postdoctoral fellow on the diatom lipids, and Dr. Elizabeth Sauer, who still works with me as a research associate on lipid desaturation.

Let's start with the story of the peculiar lipids of extremely halophilic bacteria—those strange organisms that grow quite happily in saturated salt. You find them in salt lakes such as Owens Lake in California, and in salt ponds or flats for making solar salt, for example the salt flats in San Diego or San Francisco or anyplace that has a high salt concentration, such as the Dead Sea. Incidentally, it was Dr. Ben Volcani who discovered the halophilic bacteria in the Dead Sea.

Now, the story of the halophilic lipids begins around 1958 when Dr. Norm Gibbons, head of the Microbiology Section at NRC, suggested examining the lipids of halophilic bacteria because he was convinced that they would be different from normal bacteria due to the high salt content of their growth medium. Together with postdoctoral fellows Suren Sehgal (1) and later P.S. Sastry and Leon Yengoyan (2), we began to work on the isolation and structure determination of the lipids of *Halobacterium cutirubrum*, which means the salt-loving bacterium with the red coat.

This organism is a rod-shaped bacterium with flagellae. Its outer surface or cell wall has a coarse "tweedy-pattern" and underneath is the plasma membrane which contains, in addition to the polar lipids, beautiful orange-red pigments called bacterioruberins which my colleague Dr. Santosh Kushwaha showed were C_{50} carotene-like compounds. It is these pigments that actually are responsible for the red color of these halophiles and hence for the red color of the salt water in which they grow. They also protect the cells against the harmful effects of sunlight.

Under certain conditions of growth (low aeration and high light intensity) the halophile makes an additional membrane which has a purple color. This "purple membrane" has been shown by Walther Stoeckenius in California to be a protein-vitamin A complex similar to the purple rhodopsin in the retina of the eye which is responsible for our being able to see. Stoeckenius showed that the bacteriorhodopsin was able to capture light energy and use it to produce a proton gradient across the membrane that could be used to synthesize ATP, which is the direct energy source in the cell.

The red and purple membranes can be separated by high speed centrifugation on a sucrose gradient, and can be obtained as pure fractions. We sent this purple membrane prepared from *H. cutirubrum* by Santosh Kushwaha to Stoeckenius in California, and he sent us his purple membrane preparation from *H. halobium* (a different halophile species); we both found the two preparations were indistinguishable, thus showing that there were no species differ-

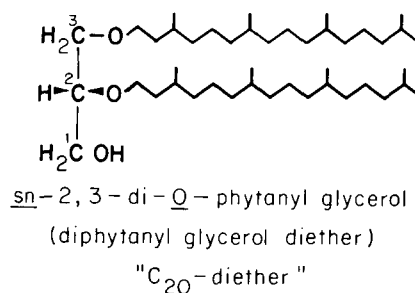

FIG. 1. Chemical structure of the diphytanyl glycerol ether from extremely halophilic bacteria.

ences in the protein part of the purple membrane from these two different halophiles. It is very curious that a rhodopsin-complex should have evolved in a primitive bacterium long before the evolution of the eye.

To return to the lipids, remember that phospholipids have fatty acids linked to glycerol by ester bonds. These are easily cleaved or hydrolyzed by acid, and one can then isolate the free fatty acids. We found to our great surprise that the lipids of *H. cutirubrum* and those of several other extreme halophiles gave no fatty acids after acid hydrolysis (1-3). Instead, we isolated a lipid that was free of phosphate and sugars and turned out to consist of two long chains linked to glycerol by ether bonds which are stable to acid or alkali (Fig. 1). This long-chain group was actually a C_{20} compound called the "phytanyl" group with 4 methyl branch groups. In fact, it was identical to the phytol group in chlorophyll after saturation of its double bond (2). This was the clue that led us to a new world of membrane lipids . . . those derived not from fatty acid esters of glycerol but from long-chain ether derivatives of glycerol.

All the polar lipids turned out to be derived entirely from this phytanyl diether of glycerol, and thin-layer chromatography (TLC) showed that there were three phospholipid components and two glycolipids, one of which was a very minor component (2-7). Structural studies by Drs. Sastry and Yengoyan (2) and later Drs. Palameta and Joo (3), showed that the major phospholipid component, which accounted for 75% of the total polar lipids, had the structure of phosphatidylglycerophosphate (PGP) (I, Fig. 2). My graduate student, Tony Hancock, later showed (4) that the other two minor phospholipids were phosphatidylglycerol (PG) (III, Fig. 2), while Paul Deroo, another graduate student, showed (5) that the main glycolipid was a sulfated three-sugar glycolipid, galactosyl-3-sulfate-mannosyl-glycosyl-diether (S-TGD) (IV, Fig. 2).

Recently, my graduate student Barry Smallbone (6) established the structure of the minor glycolipid as a sulfated four-sugar glycolipid (S-TeGD) which looked like the main sulfated three-sugar glycolipid with an added galactose sugar group (Fig. 3). These glycolipids thus would have very large polar heads.

Examination of the diether phospholipid structures in Figure 2 in comparison with the structures of normal phospholipids shows that diether phospholipids in the halophiles are the mirror images of those in all other organisms—that is, they are related as the right hand is to the left hand (Fig. 4). It is almost as if we have passed "through the looking-glass" into a world where everything is turned inside-out.

The question arises, how would these phytanyl ether lipids fit into a parallel bilayer structure? Because of the

ADVENTURES IN MEMBRANELAND

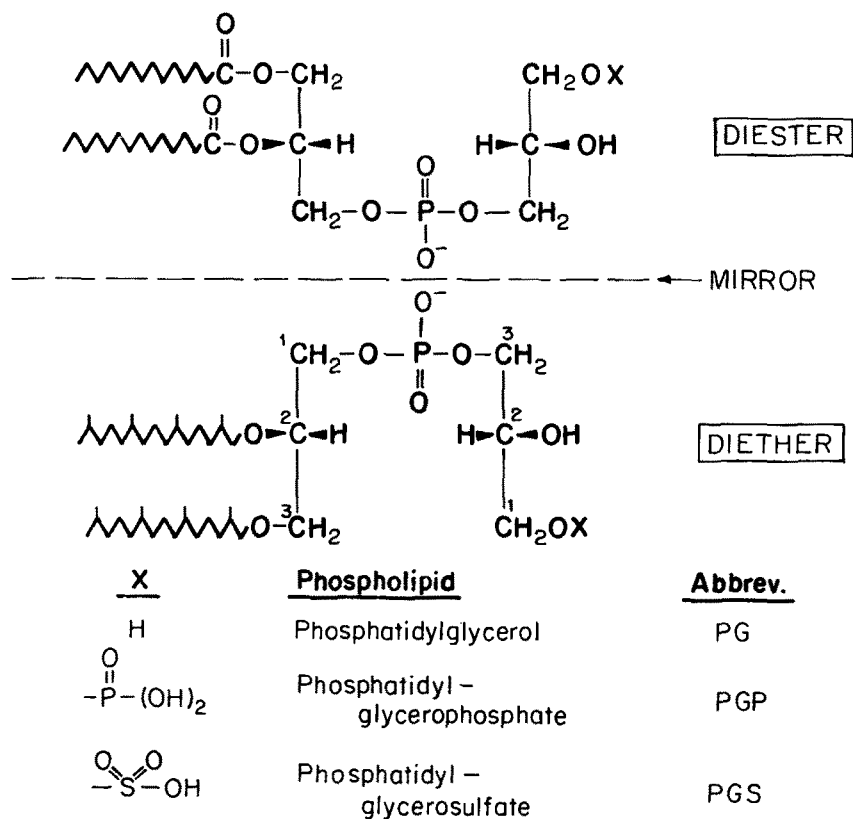

FIG. 4. Stereoconfiguration of diphytanyl glycerol ether derived phospholipids compared to normal diester phospholipids.

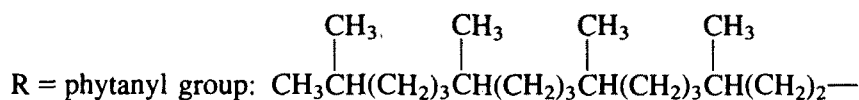
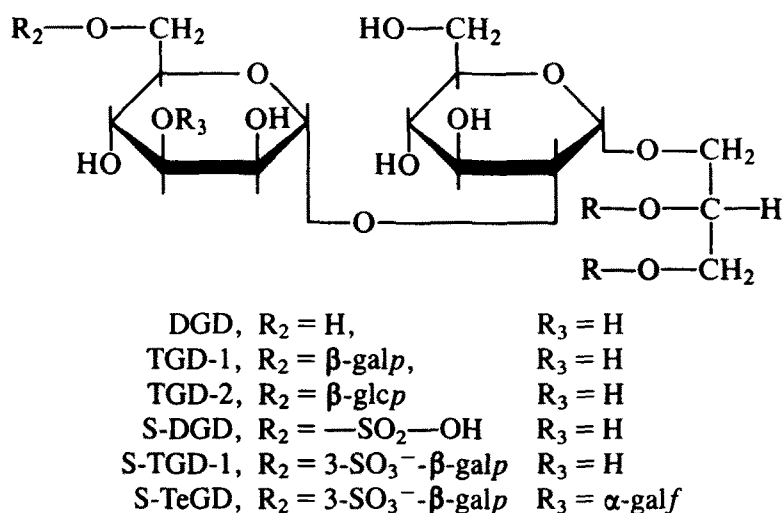

FIG. 5. Structures of glycolipids in extremely halophilic bacteria from different sources. DGD, diglycosyl diether; TGD-1 and TGD-2, triglycosyldiether; S-DGD, sulfated diglycosyldiether; S-TGD-1, sulfated triglycosyl diether; S-TeGD, sulfated tetraglycosyl diether. The extreme halophiles fall into three groups depending on their major glycolipids: I (*H. salinarium* group), S-TGD, S-TeGD; II (Dead Sea group), TGD-2, DGD; III (R-4 group), S-DGD (from Ref. 12).

TABLE I

Polar Lipid Composition of Strain R-4 compared to *H. cutirubrum* and *H. Marismortui*^a

Polar lipids	Lipid composition (mole %)		
	Strain R-4	<i>H. cutirubrum</i>	<i>H. marismortui</i>
Phosphatidylglycerol	44	4	11
Phosphatidylglycerophosphate	30	70	62
Phosphatidylglycerosulfate	—	4	17
Glycodiosyl diether sulfate	25	—	n.d.
Glycotriaosyl diether sulfate	—	21	—
Glycodiosyl diether	1	trace	n.d.
Glycotriaosyl diether	—	trace	11
Number of negative charges per mole ionic lipid ^b	1.3-1.6	1.7-2.4	1.7-2.3

^aData from Ref. (11).

^bThe first and second values given are calculated on the basis of 2 and 3 negative charges per molecule of phosphatidylglycerophosphate, respectively.

branched chain structure of the phytanyl groups, the hydrophobic portion of the phospholipids would have a thicker cross-section than that of the polar head. However, in the major glycolipid the three sugar groups form a sufficiently large head group to more than compensate for the thickness of the hydrophobic group. So by inserting one glycolipid molecule for every three phospholipid molecules, we should achieve parallel bilayer structure.

Electron micrographs of a 3:1 mixture of phospholipid to glycolipid show that typical liposomes with multibilayer structures are indeed formed (8). This has been confirmed recently by Barry Smallbone using freeze-fracture electron microscopy and by Ian Smith at NRC using ³¹P-NMR (9).

The halophiles discussed so far are found in salt flats which are in a sense man-made or artificial. For comparison we recently have examined the lipids of a halophile from the Dead Sea, called *Halobacterium marismortui* (10). Dr. Robert Evans, who was a post-doc with me a few years ago, found that this halophile had the same phytanyl ether lipids as *H. cutirubrum* except that the glycolipid sulfate (S-TGD, IV, Fig. 2) was completely absent and was replaced by a non-sulfated glycolipid, having the structure glycosyl-mannosyl-glycosyl-diphytanyl glycerol ether.

We also examined the lipids of several halophiles from Spanish salt flats, particularly one designated R-4 (11). Here the usual glycolipid sulfate (S-TGD) was again absent, but this time was replaced by another one—a sulfated diglycosyl diether (S-DGD) with the structure mannosyl-6-SO₄-glycosyl diether.

Comparing the membrane polar lipids of R-4, *H. marismortui* and *H. cutirubrum* (Table I), we see that in spite of quantitative and qualitative differences both membranes have the same number of negative charges per mole lipid and a similar proportion of sulfate groups, so that the overall effect on the two membranes would be essentially the same and consistent with life in a high salt environment.

More than 15 examined species of halophiles from various salt flats, salt lakes and the Dead Sea have essentially the same phospholipids (PGP, PG & PGS), but seem to fall into three groups (I-III) depending on their glycolipid composition (12) (Fig. 5). The glycolipids seem to be derived from a basic diglycosyl diether (mannosyl-glycosyl diether) by substituting a sulfate or a sulfated sugar or a sugar at the 6- or 3-positions of the mannose (Fig. 5). So here is a project for the future: what is the function of these glycolipids,

and how is their biosynthesis regulated?

What are the advantages to the extreme halophiles to have these strange lipids in their membranes? First, the saturated hydrocarbon chains impart stability to oxidative degradation and the ether linkages impart stability to acid or alkali, which would be advantageous to halophilic organisms growing as they do over a wide range of pH. The unnatural configuration of the phospholipids makes them resistant to attack by animal, plant or bacterial enzymes. The high negative charge density on the lipids would be advantageous in a high salt medium because it would be neutralized by the high sodium ion concentration, thus providing for a stabilized lipid bilayer. The negative phosphate groups also would allow interaction with anionic charged sites in the membrane proteins, perhaps through Mg-chelation. Differential affinities of sulfate and phosphate groups for Na⁺ and K⁺ ions may aid in selective ion transport across the membrane.

Another function that has exciting possibilities is that the acidic phospholipid PGP may help maintain the proton gradient formed by the purple membrane. We showed years ago that at pH 7 PGP has only two of its phosphate groups in dissociated form. This could allow it, in bilayer form, to conduct protons around the outer leaflet of the bilayer, thus maintaining the gradient rather than allowing the protons to diffuse out of the bilayer (Fig. 6).

For many years we believed that these ether lipids were unique and present only in extreme halophiles. This was based on surveys of many different kinds of bacteria. However, several years ago reports appeared by Langworthy in the United States, Da Rosa in Europe and others that thermoacidophilic bacteria that grow in acidic hot springs also have strange alkyl ether lipids.

Soon afterward ether lipids were discovered, by Tom Tornabene, a former post-doc of mine, and Tom Langworthy, in another class of bacteria, the methanogens, that grow in sewage and produce methane. These three classes of bacteria, extreme halophiles, thermoacidophiles and methanogens recently have been classified as "Archaeobacteria," which represent a separate group of organisms distinct from both Prokaryotes and Eukaryotes.

The structure of the ether portion of the lipids of both methanogens and thermoacidophiles (Fig. 7) looks like a doubled-up version of the diphytanyl glycerol ether in halophiles, and was called the biphytanyl diglycerol tetraether.

ADVENTURES IN MEMBRANELAND

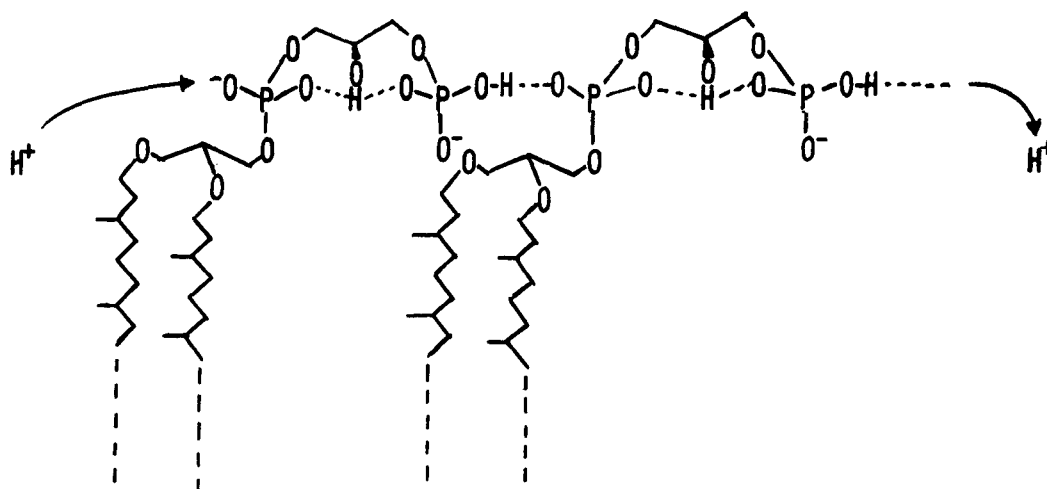
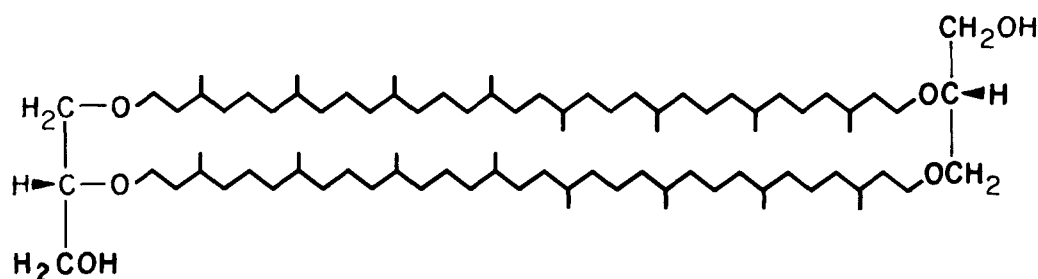

FIG. 6. Proposed model of PGP bilayer showing possible proton conductance.



di-biphytanyl diglycerol tetraether
("C₄₀-tetraether").

FIG. 7. Chemical structure of the di-biphytanyl diglycerol tetraether derived from lipids of methanogens and thermoacidophiles.

Santosh Kushwaha and I decided to examine the lipids of a methanogenic bacterium called *Methanospirillum hungatei*, in more detail, with the collaboration of Dennis Sprott at NRC who grew this organism for us. Within a relatively short time, Santosh had isolated all the polar lipids of this bacterium, separated them and had worked out the chemical structures of all seven of them (13) (Fig. 8).

You see that four of them are derived from the tetraether while three are derived from the diether. The major components turned out to be the glucosyl-galactosyl tetraether glycerophosphate (PGL-I) and the digalactosyl tetraether glycerophosphate (PGL-II), followed by the corresponding glycolipids made from the diphytanyl ether (DGD-I and DGD-II, respectively) and the diphytanyl ether analog of phosphatidylglycerol which we saw before in the halophiles; finally there are traces of derivatives of PGL-I and PGL-II in which the glycerolphosphate groups are absent.

The tetraether lipids are very interesting because they look like they should behave as covalently bonded asymmetric lipid bilayers. Such molecules should impart great stability and rigidity to the membrane, as would be needed by thermoacidophiles growing at high temperatures, or by methanogens, producing methane that could dissolve in and distort the membrane.

Another interesting point is the question of the biosynthesis of these tetraether lipids. Examination of their structures suggests that they might be made by tail-to-tail linkage of appropriate diether lipids.

PGL-I, for example, could be made by tail-to-tail condensation of a molecule of the DGD-I and phosphatidylglycerol (PG) (Fig. 9). Similarly, PGL-II could be made by condensation of DGD-II and PG. You can see that we are going to have a lot of interesting things to follow up with these lipids.

It is clear now that our findings on the lipids of halophiles and methanogens support their classification as archaebacteria, together with the thermoacidophiles. I would go one step further to say that the extreme halophiles may be older than or the precursor of the other two, for diethers must have preceded tetraethers. Time alone will tell whether this is true.

Now, I want to relate another little story. This began in 1964 when Ben Volcani invited me to La Jolla to study the membrane lipids of diatoms—which are phytoplankton-like creatures with silica cell walls having characteristic beautiful geometric shapes and patterns. They are found mostly in the sea where they serve as the main source of food for higher marine organisms. We found (14) that the diatoms had lipids similar to those of algae and higher plants, such as phosphatidylglycerol, mono- and digalactosyl diglyceride and sulfoquinovosyl diglyceride. We also found several ³⁵S-labelled unidentified spots on chromatograms of total lipids from cells grown in medium containing ³⁵S-sulfate. This meant that we were dealing with sulfolipids, and one of these had chromatographic properties very similar to lecithin.

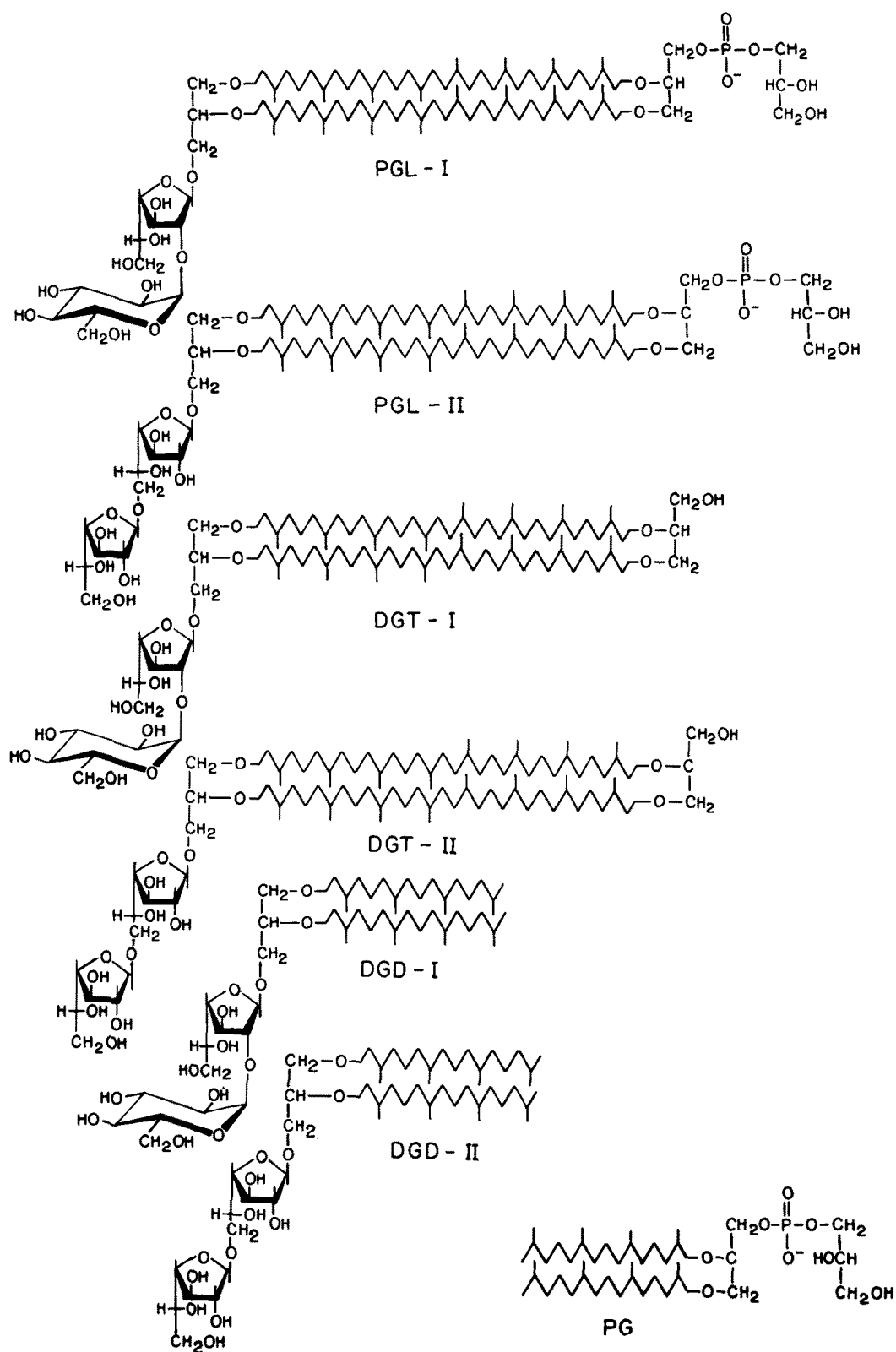

FIG. 8. Chemical structures of the polar lipids of methanogenic bacteria (from Ref. 13).

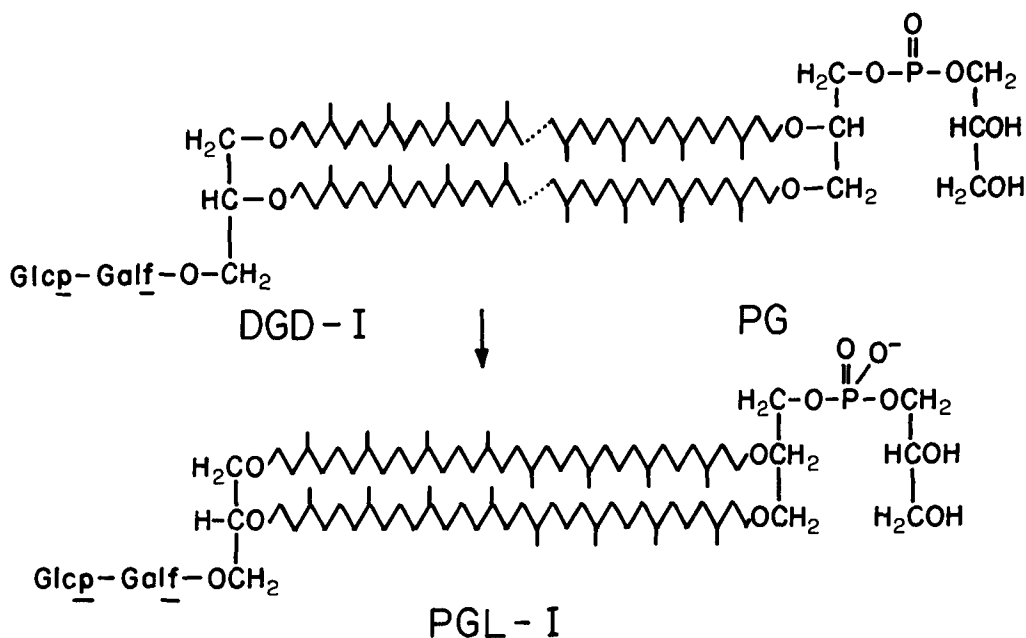
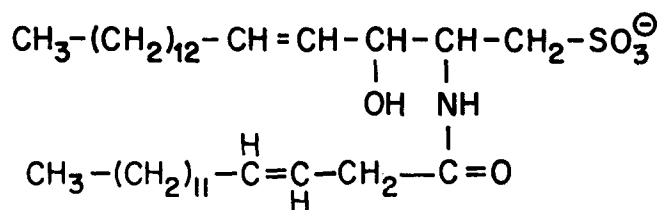

FIG. 9. Proposed mechanism for biosynthesis of the major C_{40} tetraether lipid (PGL-I) in methanogens.

SULFOLIPIDS of *N. alba*

N-acyl-1-deoxysphinganine-1-sulfonate



Codisterol sulfate

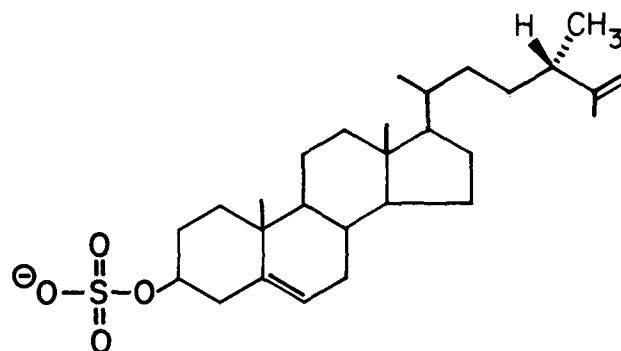

Phosphatidyl S,S-dimethyl mercaptoethanol

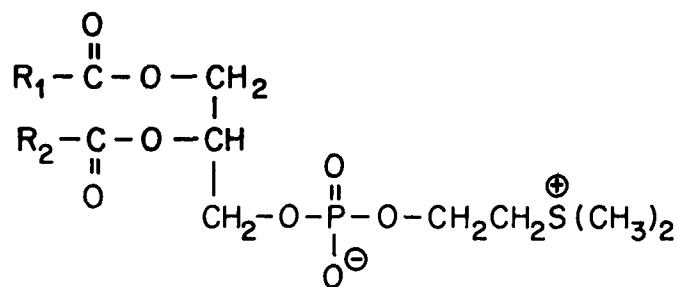

Sulfoquinovosyl diglyceride

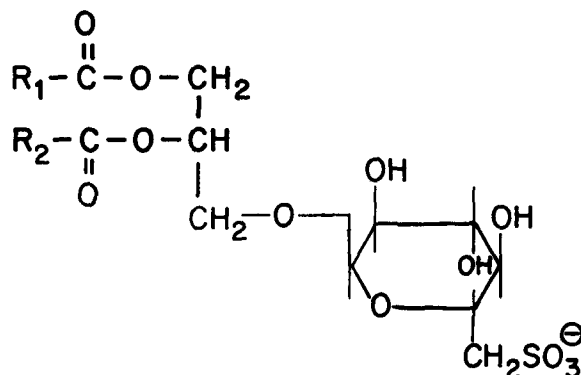

FIG. 10. Structures of the major sulfolipids in the diatom *Nitzschia alba* (from Ref. 15).

Well, 10 years later, along came Robert Anderson as a post-doc and he was able to isolate and identify all of the sulfolipid components from a diatom called *Nitzschia alba* (15) (Fig. 10). But I want to concentrate on the lecithin-like sulfolipid. We found to our great surprise that the compound completely lacked nitrogen but contained one atom each of sulfur and phosphorus. Through degradative and spectrometric studies it gradually became clear that we were dealing with a lecithin analog in which the nitrogen was replaced by sulfur, that is, a sulfonium analog, phosphatidylsulfocholine (Fig. 10). This finding was especially exciting since the sulfonium analog in *N. alba* completely replaced the lecithin usually found in plants or algae. The first thing that had to be done, however, was to confirm the sulfonium structure by chemical synthesis.

It was clear that it should be possible to synthesize the analog in the same way as lecithin. Well, along came Paul Tremblay as a graduate student and he proceeded to synthesize a series of sulfonium analogs of phosphatidylcholine with different fatty acid chains, C₁₄, C₁₆, C₁₈, etc. (16). The route used was to condense phosphatidic acid with sulfocholine by the analogous method devised by Aneja (17) for lecithin synthesis. Comparison of the synthetic and natural phosphatidylsulfocholines showed they were identical (except for the particular fatty acid present) and confirmed our previous structure assignment (15). Now the question arose, how can the sulfonium analog substitute for lecithin in membranes?

Models of the sulfonium and ammonium analogs (Fig. 11) showed that the polar head of the sulfonium analog was about 20% larger than that of lecithin. We then began a study of the physical properties of the sulfonium analog (18). First Paul Tremblay showed by freeze-etch electron microscopy that the sulfonium analog formed multilayer liposomes that were indistinguishable from those formed by lecithin.

Next, Tremblay showed by several techniques that the transition temperatures of the sulfonium analogs were only about 2-3°C higher than those of the corresponding lecithins. He also showed that cholesterol interacted with the sulfonium analog to abolish the gel to liquid phase transition, and Bob Bittman (19) then showed that cholesterol lowered the permeability of bilayers precisely as with lecithin. Finally, Tremblay was able to grow yeast cells in a medium containing sulfocholine instead of choline and found that the cells grew normally in spite of an almost complete replacement of lecithin by phosphatidylsulfocholine.

So, we must conclude that the molecule of phosphatidylsulfocholine is sufficiently similar to that of lecithin to be able to substitute for it in natural membranes, even though it is physically and chemically distinguishable from its analog.

The question then arose whether this sulfonium analog (PSC) was present in other diatoms and how widespread it was in other marine organisms that feed on diatoms. Together with Paul Tremblay, Seiseke Ito from Obihiro, Japan, and a post-doc from France, Philippe Bissere, we developed an NMR procedure for quantitation of PSC in presence of PC.

When we applied this procedure to a variety of diatoms and other marine organisms, we found to our disappointment that PSC was not universally distributed among the diatoms we looked at and was present in appreciable propor-

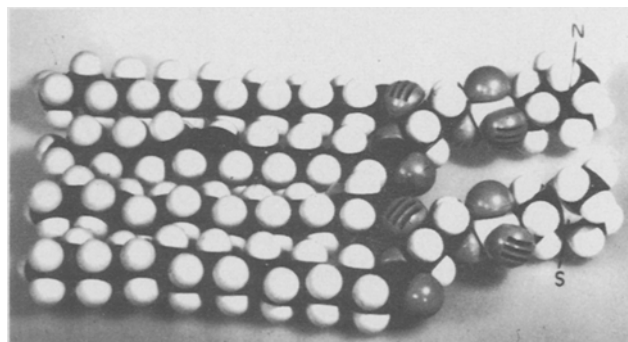

FIG. 11. Molecular models of phosphatidylcholines (top) and phosphatidyl sulfocholine (bottom) (from Ref. 18).

tions in only one of the marine organisms examined—jumbo shrimp (but surprisingly not in small shrimp)—that are known to feed on diatoms. Clearly, we must do a more extensive survey of marine organisms and we also must find out how the PSC is biosynthesized. So far we have shown that diatoms can make sulfocholines from cysteine and methionine (20), and we recently showed (Tremblay, Kates and Volcani, unpublished results) that they can incorporate sulfocholine into PSC, presumably by the Kennedy Pathway. The final enzyme in the pathway, phosphocholine transferase, probably can utilize sulfocholine as well as choline, as we found in the sulfocholine replacement studies with yeast that I mentioned earlier. So, as you see I have my work cut out for me for the next few years at least!

In conclusion, regarding my future work, I like to think that, in Newton's words, I shall probably continue "to play at the seashore finding a prettier shell here or a brighter pebble there while all around lies the great ocean of Truth yet undiscovered."

REFERENCES

1. Sehgal, S.N., M. Kates and N.E. Gibbons, *Can. J. Biochem. Physiol.* 40:69 (1962).
2. Kates, M., L.S. Yengoyan and P.S. Sastry, *Biochim. Biophys. Acta* 98:252 (1965).
3. Kates, M., B. Palameta, C.N. Joo, D.J. Kushner and N.E. Gibbons, *Biochemistry* 5:4092 (1966).
4. Hancock, A.J., and M. Kates, *J. Lipid Research* 14:422 (1973).
5. Kates, M., and P.W. Deroo, *J. Lipid Research* 14:438 (1973).
6. Smallbone, B.W., and M. Kates, *Biochim. Biophys. Acta* 665: 551 (1981).
7. Kates, M., *Prog. Chem. Fats other Lipids* 15:301 (1978).
8. Chen, J.S., P.G. Barton, D. Brown and M. Kates, *Biochim. Biophys. Acta* 353:202 (1974).
9. Ekiel, I., D. Marsh, B.W. Smallbone, M. Kates and I.C.P. Smith, *Biochem. Biophys. Res. Commun.* 100:105 (1981).
10. Evans, R.W., S.C. Kushwaha and M. Kates, *Biochim. Biophys. Acta* 619:533 (1980).
11. Kushwaha, S.C., M. Kates, G. Juez, F. Rodriguez-Valera and D.J. Kushner, *Biochim. Biophys. Acta* 711:19 (1982).
12. Kushwaha, S.C., G. Juez-Perez, F. Rodriguez-Valera, M. Kates and D.J. Kushner, *Can. J. Microbiol.* 28:1365 (1982).
13. Kushwaha, S.C., M. Kates, G.D. Sprott and I.C.P. Smith, *Biochim. Biophys. Acta* 664:156 (1981).
14. Kates, M., and B.E. Volcani, *Biochim. Biophys. Acta* 116:264 (1966).
15. Anderson, R., M. Kates and B.E. Volcani, *Biochim. Biophys. Acta* 528:89 (1978).
16. Tremblay, P.-A., and M. Kates, *Can. J. Biochem.* 57:595 (1979).
17. Aneja, R., and J.J. Chadha, *Biochim. Biophys. Acta* 248:455 (1971).
18. Tremblay, P.-A., and M. Kates, *Chem. Phys. Lipids* 28:307 (1981).
19. Bittman, R., A.M. Leventhal, S. Karp, L. Blau, P.-A. Tremblay and M. Kates, *Chem. Phys. Lipids* 28:323 (1981).
20. Anderson, R., M. Kates and B.E. Volcani, *Biochim. Biophys. Acta* 473:557 (1979).